

FEATURES & BENEFITS

- Lock top box
- The D Buffer offers 360 degree protection, minimising wall damage
- Fully welded steel construction, with durable powder coat finish
- Greater storage capacity, lighter in weight and easier to push compared to HDPE rivals
- Anti-skid, non-marking castors with roller bearings allow for easy manoeuvrability
- Deep top tray provides great capacity for required amenities
- Available in multiple sizes & designs to meet the various site challenges presented by different properties
- Stock colours available in black and primrose or customised colour available by special order
- Various styles & colours of linen bags available to suit multiple laundering processes used throughout different properties

WAGEN MAIDS CART 4 STAR

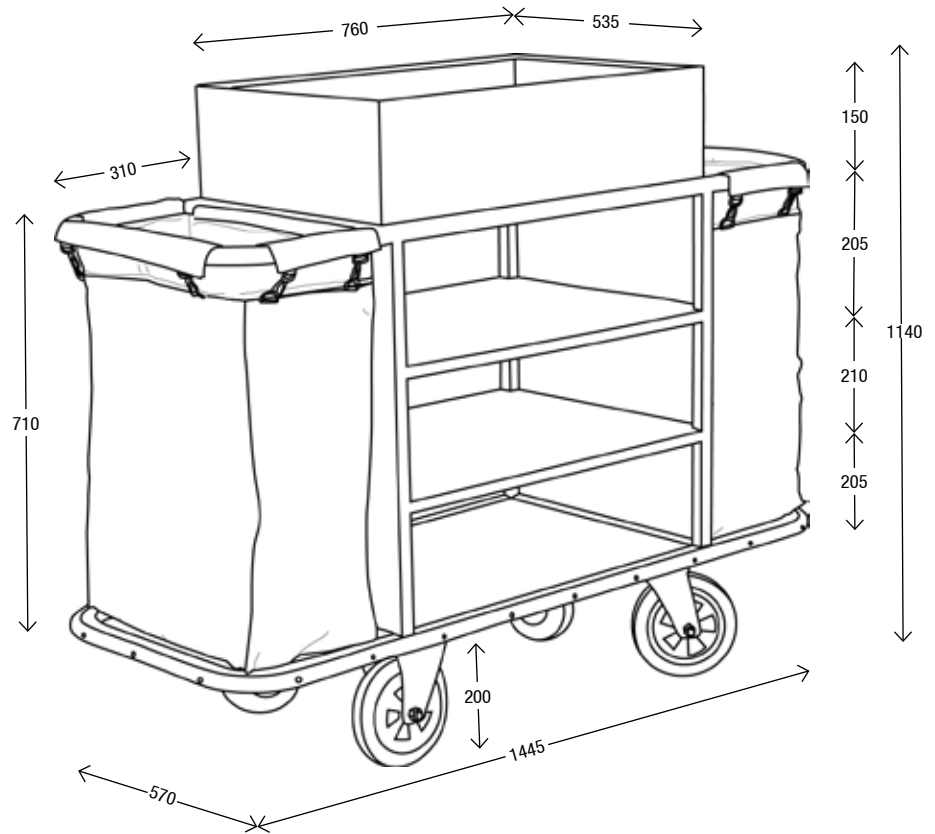

ITEM CODE	HOS-101-MAIDSCART
DIMENSIONS	1445 L x 570 W x 1140 H mm
WEIGHT	60 kg
CAPACITY	400 kg
MATERIALS	200mm grey Wagen non-marking casters with roller bearings Powder coated steel
COLOUR	Black Primrose Custom colours available
OPTIONAL EXTRAS	Lock top box Hammer lock brake Organisational dividers